

VILLAGE OF LODI  
SIDEWALK PERMIT

Issued to:

- a. Name \_\_\_\_\_  
b. Address: \_\_\_\_\_  
c. Telephone: \_\_\_\_\_  
    Daytime: \_\_\_\_\_  
    Evenings and Weekends: \_\_\_\_\_

For sidewalk to be constructed, installed or repaired at: \_\_\_\_\_

---

1. This permit constitutes authority for the person to whom it is issued to construct, install or repair a sidewalk at the location stated above, provided that such construction, installation or repair is in full compliance with the provisions of the Codified Ordinances of the Village of Lodi, Ohio, and particularly Chapter 1286 of the Planning and Zoning Code. This permit is issued pursuant to Section 1286.05 of said Planning and Zoning Code and is issued without fee.
2. Construction, installation and repair of sidewalks by a property owner upon his, her or its own property do not require the posting of financial security. Contractors constructing, installing or repairing sidewalks on premises other than their own must post financial security as set forth in Section 1286.08(a) of the Planning and Zoning Code of the Village.

By: \_\_\_\_\_  
Zoning Inspector and/or Village Superintendent  
Village of Lodi, Ohio

INSPECTION DATE: \_\_\_\_\_  
APPROVED: \_\_\_\_\_ DISAPPROVED: \_\_\_\_\_  
REASON: \_\_\_\_\_

VILLAGE OF LODI, PO BOX 95, LODI, OH 44254 330-948-2040 330-948-3017 (Fax)

1993 Replacement

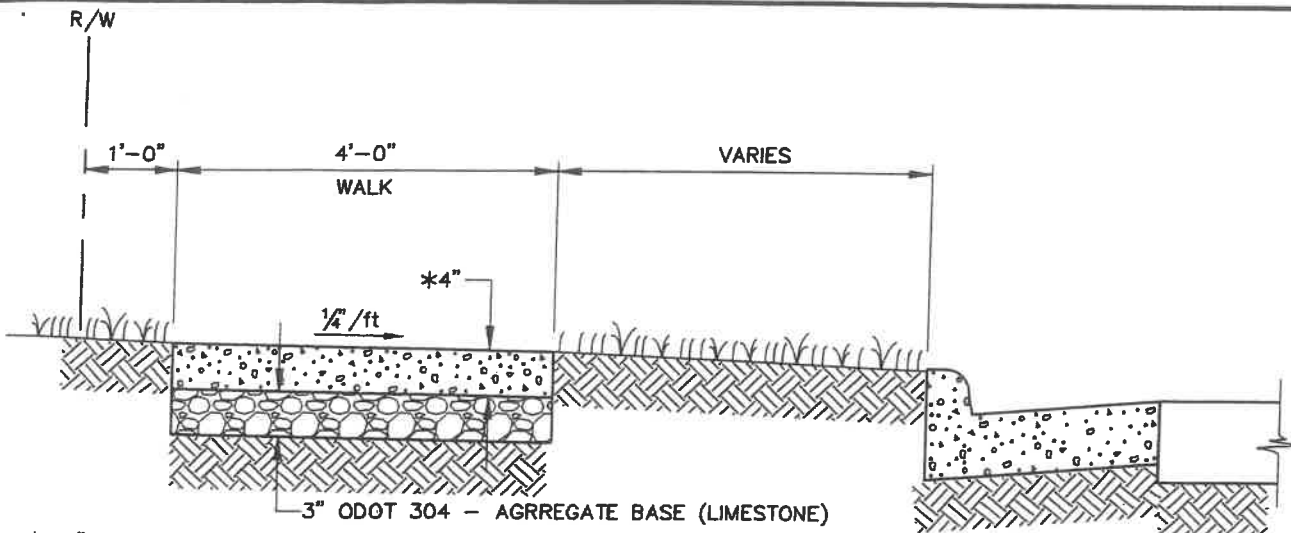

\* 6" MIN. FOR WALKS ACROSS DRIVES AND HANDICAP RAMPS

**TYPICAL DETAIL**

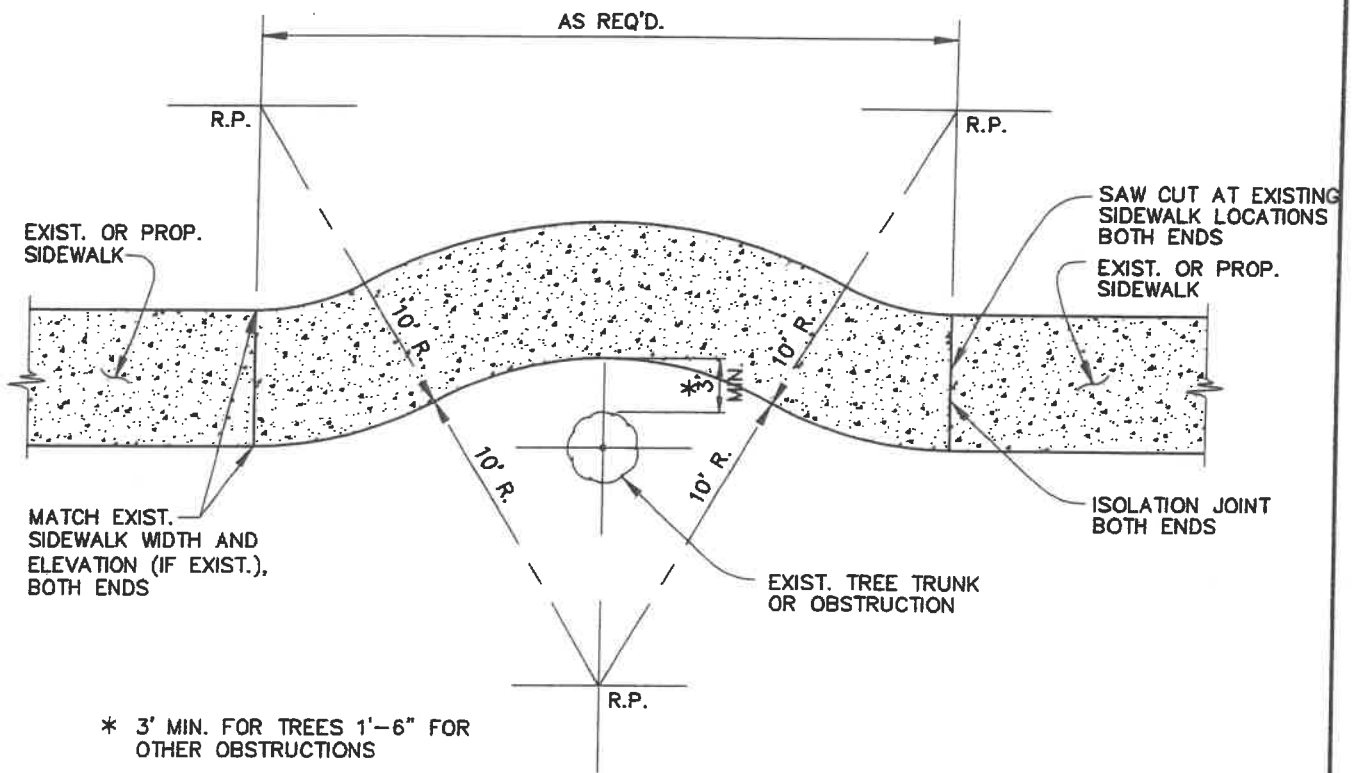

**SIDEWALK RE-ALIGNMENT DETAIL  
(USE ONLY WHEN APPROVED BY VILLAGE)**

**VILLAGE OF LODI  
STANDARD CONSTRUCTION DRAWINGS**

SIDEWALKS

SCALE	DATE	SHEET
NONE	APRIL 2017	R-2

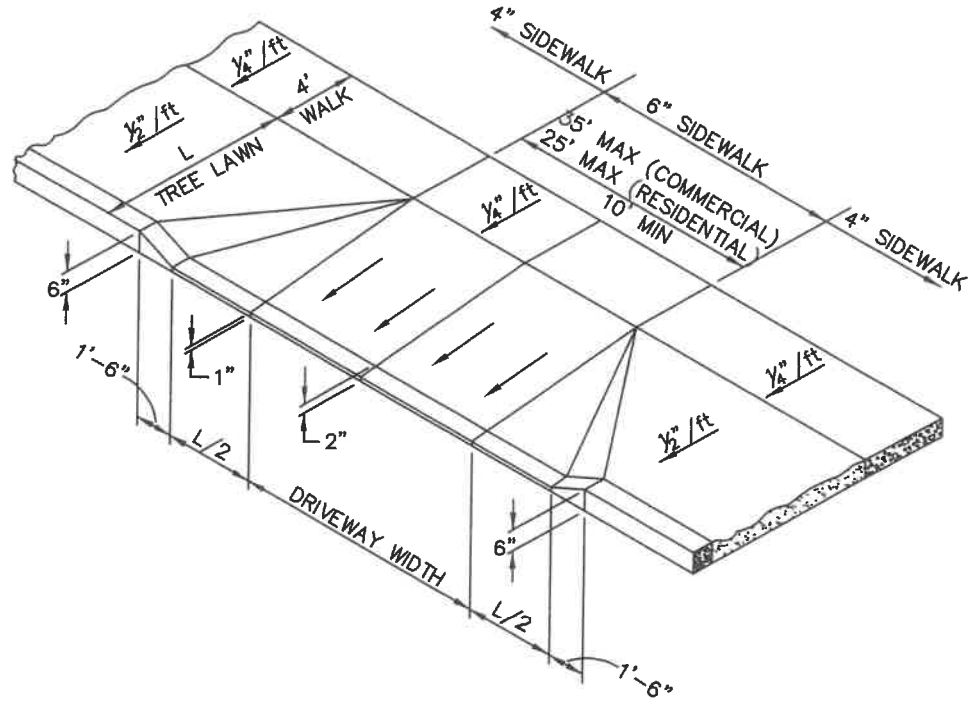

ISOMETRIC VIEW

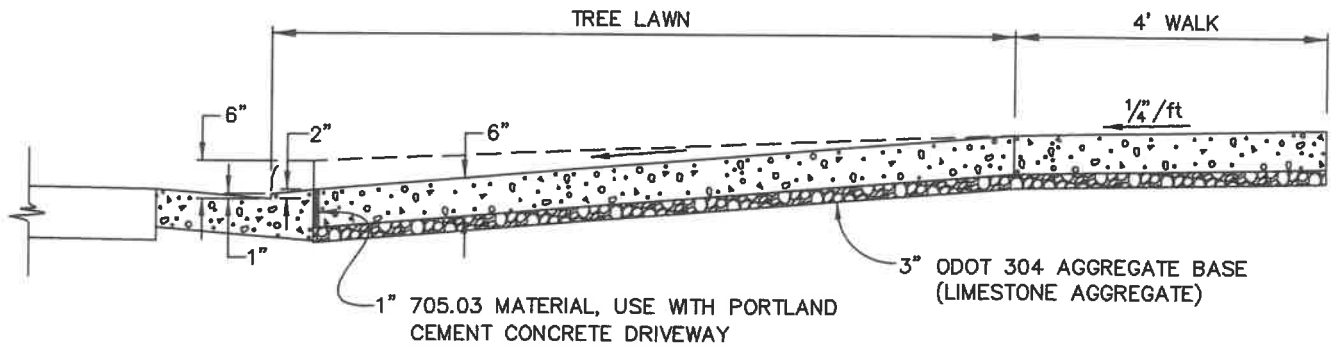

DRIVEWAY PROFILE

VILLAGE OF LODI  
STANDARD CONSTRUCTION DRAWINGS

DRIVEWAYS

SCALE	DATE	REVISION
NONE	JANUARY 2020	R-1

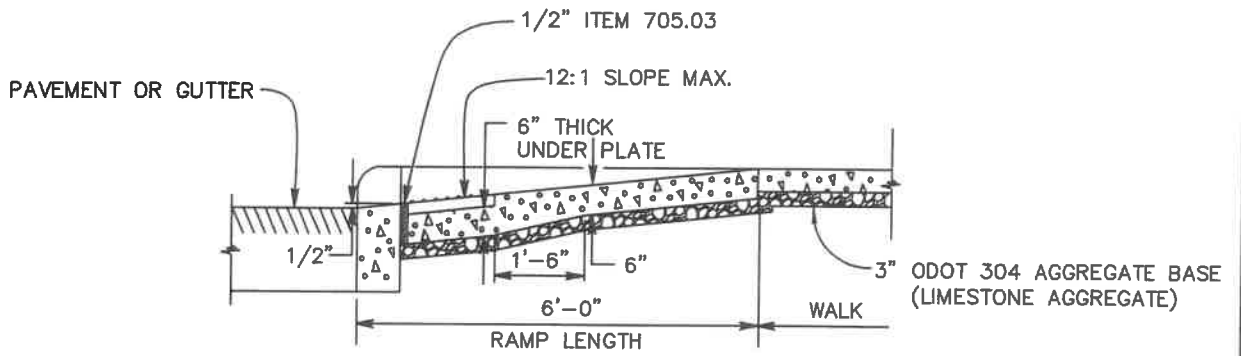
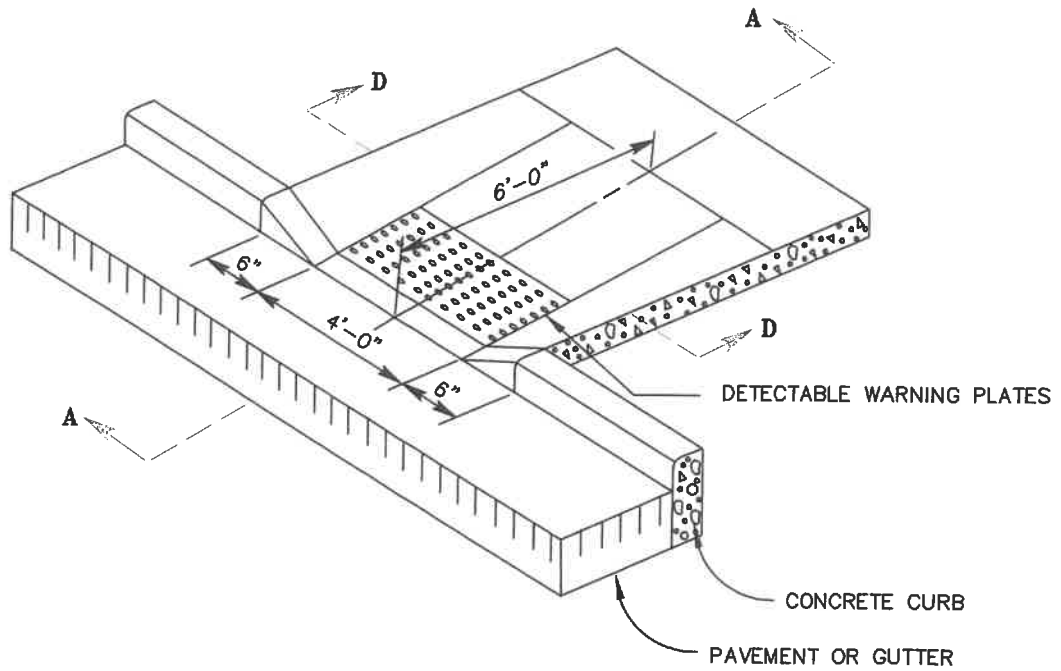

SECTION A-A

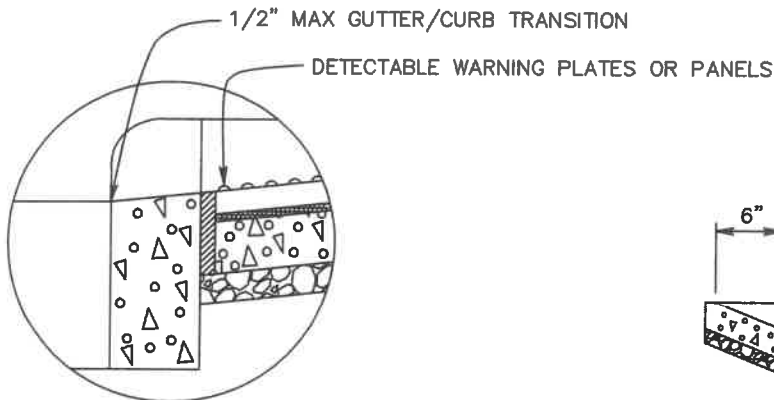

DETAIL A

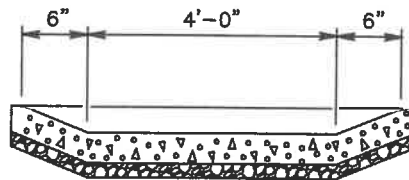

SECTION D-D

DETECTABLE WARNINGS (TRUNCATED DOMES) ARE TO BE INSTALLED IN THE LOCATION SHOWN. DIMENSIONS OF THE DOMES ARE 24" FROM THE BACK OF THE CURB BY THE WIDTH OF THE RAMP.

VILLAGE OF LODI  
STANDARD CONSTRUCTION DRAWINGS

SIDEWALK CURB RAMPS

SCALE	DATE	SHEET
NONE	JANUARY 2020	R-3

# RECORD OF ORDINANCES

ARRETT BROTHERS, PUBLISHERS, SPRINGFIELD OHIO

Form 6220

Ordinance No. 1826

Passed March 15, 1993

AN ORDINANCE OF THE VILLAGE OF LODI, MEDINA COUNTY, OHIO, ADOPTING THE SIDEWALK SPECIFICATIONS WHICH ARE ATTACHED HERETO AND FULLY INCORPORATED HEREIN BY REFERENCE.

WHEREAS, Council deems it advisable to have sidewalk specifications for the repair and maintenance of existing sidewalks and for the construction and installation of sidewalks for new residences and for new commercial and industrial development; and

WHEREAS, Council hereby adopts the specifications attached hereto and incorporated by reference.

NOW, THEREFORE, BE IT ORDAINED BY THE COUNCIL OF THE VILLAGE OF LODI, OHIO, that:

1. The specifications hereto attached are fully incorporated herein by reference.
2. All repair or replacement of existing sidewalks within the Village and all construction and installation of sidewalks for new residences and for new commercial and industrial development shall be performed in accordance with the specifications.
3. This ordinance shall be in full force and effect at the earliest period provided by law.

PASSED: 3-15-93

R. A. Bell  
R. A. Bell, Mayor

ATTEST:

Annette Geissman  
Annette Geissman  
Clerk-Treasurer

Thomas J. Filous  
Thomas J. Filous  
Law Director

## VILLAGE OF LODI SIDEWALK SPECIFICATIONS

### SPECIFICATIONS FOR THE REPAIR OF EXISTING SIDEWALKS AND THE CONSTRUCTION AND INSTALLATION OF SIDEWALKS FOR NEW RESIDENCES AND FOR NEW COMERCIAL OR INDUSTRIAL DEVELOPMENT

#### Section 1 Sidewalk Specifications Established.

Sidewalk Specifications are hereby established for streets and avenues in the Village. When constructed, they shall be constructed and maintained in good repair by the abutting property owners at their expense, as is and may be provided by law.

The adoption of these specifications does not mandate the installation of sidewalks for developed lots. These specifications apply to the repair or replacement of existing walks, installation of new walks when a new lot is developed (built on), and when, by separate legislation of necessity, new installation is determined to be required.

#### Section 2 Elevation.

Sidewalk elevations will be determined by the Village. When constructed or repaired, sidewalks shall be constructed and repaired so as to have a cross-slope of one-fourth inch vertical to one foot horizontal, sloped towards the curb or roadway. (1/4" means 1 inch to 4 feet).

#### Section 3 Owner to Build or Repair; Remedy of Village.

When constructed or repaired, each and every sidewalk or part thereof shall be constructed or repaired by the owner of the abutting property within such time after legal notice of the passing of an Ordinance requiring the same according to the specifications set forth herein or as they may be amended. The provisions of the Ohio Revised Code are hereinafter incorporated by reference and all acts, procedures, and requirements shall be adhered to by the Village.

#### Section 4 Sidewalks to be Inspected.

The construction and/or repair of sidewalks shall be inspected by the Village Street Superintendent or other designated representative, and in accordance with the specifications and plans on file with the Village of Lodi.

#### Section 5 Permit to Install Sidewalk.

No person, firm or corporation shall construct, install or repair any sidewalk on any street until he has first obtained a permit from the Village of Lodi for such purposes. There shall be no cost for the permit.

Section 6 Sidewalk Construction; Installation.

All sidewalks hereinafter constructed or repaired along accepted streets and avenues of the Village shall be of Portland cement concrete.

The following specifications and standards for the construction, repair, and installation of concrete sidewalks are hereby adopted for the Village:

A. Definitions.

1. "Village" – the Village of Lodi or its authorized representative or other person appointed by it.
2. "Contractor" – the party or parties contracting to do any work described herein, or authorized representatives of such part or parties, or the owner of the adjacent property doing his own work.
3. "Specifications" – the State of Ohio Department of Transportation (ODOT) Construction and Material Specifications, latest edition. A copy is available for inspection at the Village of Lodi, Planning Commission Office or by direct purchase from the:

Ohio Department of Transportation  
Bureau of Contract Sales  
PO Box 899  
Columbus, OH 43216-0899  
Phone: 614-466-3778

4. "Sidewalk Sections"- Sidewalk Sections shall be as set forth in Appendix "C" which is attached hereto and in accordance with the drawings and notes contained therein.

B. Materials.

1. Portland Cement Concrete

ODOT 499 – Class "C" Limestone

- a. Cement 600 lbs/cy
- b. Entrained Air  $6 \pm 2$  percent
- c. Maximum slump 4"

2. Preformed Filler (joint)

ODOT 705.03

3. Curing Materials

ODOT 705.07 (Type #2)

4. Forms

Wood or steel profiled to suit conditions

5. Thickness and Proportions

The sidewalks shall consist of one course of concrete of not less than four inches in thickness. When the locations of driveways are known, the thickness of the walks shall be increased to not less than six inches.

6. Width

Sidewalks on all new streets shall have a width of four feet (4'). Sidewalks on existing streets should be as wide as the existing walks, but not less than 3'5" feet. On new or existing streets, where a sidewalk is required to be constructed directly adjacent to the curb, the minimum width shall be five feet (5). These sidewalk widths shall be enforced unless otherwise provided by ordinance.

C. Execution

1. Forming

- a. Secure forms to correct location, dimensions and profile.
- b. Assemble form work to permit easy stripping and dismantling without damaging concrete.
- c. Place preformed filler vertical in position in straight lines. Secure to form work during concrete replacement.
- d. Coat concrete contact surfaces of forms with release oil to prevent bond with sidewalk.

2. Preparation

- a. Moisten sub-base to minimize absorption of water from fresh concrete.
- b. Notify Village Street Superintendent a minimum of 24 hours prior to concrete placement (for inspection purposes).

3. Concrete Placement

- a. The freshly mixed concrete shall be placed immediately on the prepared sub-grade, the edges adjacent to the forms shall be thoroughly spaded and the entire area tamped sufficiently to produce a compacted single layer slab. It shall then be



struck with a crosswise sawing motion and subsequently floated until the surface is true and has a sandy texture.

4. Joints

- a. Place preformed joints at 20 foot intervals. Align with curb, gutter and sidewalk joints.
- b. Place preformed joint filler between paving components and buildings or other appurtenances.
- c. Provide scored or sawn joints in accordance with the standards as set forth in Appendix "C".
- d. Place curing compound on exposed concrete surfaces immediately after finishing per manufacturer's instructions.

5. Protection

Immediately after placement, protect site work from premature drying, rainfall, excessively hot or cold temperatures (below 40 F), and physical or mechanical injury.

Section 7      Curb Ramps.

1. Concrete curb ramps shall be required at all street intersections locations and/or where a proposed crosswalk will be located so as to provide a uniform slope between the sidewalk elevation and the street elevation.
2. The construction materials for curb ramps shall conform to the requirements as described for sidewalk construction and installation. The finish shall be rougher than the adjacent sidewalk and obtained by coarse brooming transversely to the curb ramp slope.
3. Installation of curb ramps shall conform to the standard detail as shown on drawing No. 3.
4. All construction, installation, and repair shall be in accordance with all state and federal laws and regulations as they presently exist or as they may hereafter be adopted or amended. Therefore, these specifications shall be superseded by any such laws or regulation.
5. If curbs are to be installed on existing dedicated streets, the Village will pay the cost of curb installation. For any new development, the developer will install and pay for curb installation according to these specifications.

In order to accommodate the placement of any sidewalk, the Village will pay for the expense of moving fire hydrants, poles, guy wires, or other utilities. Further, if a tree is located in the right-of-way and in order to complete the installation the tree must be removed, the Village will pay for the cost of the removal.

6. The Village Street Superintendent shall make available the Village map information and certify to the owner or the owner's contractor the street right-of-way location.

**Section 8**      Existing Sidewalk Repair.

1.      Destruction or removal of sidewalk.

No person, firm or corporation shall dig, remove, carry away or caused to be dug any stone, earth, sand, gravel, cement or other material constituting a sidewalk. However, permission may be given by the Village to remove and/or replace a portion of any sidewalk upon the applicant executing and delivering to the Village a surety company bond in the sum of One Thousand Dollars (\$1,000.00) conditioned to the effect that the applicant and his sureties will save the Village harmless from any claim, action, or demand arising either directly or indirectly from the removal, excavation, or repair of such sidewalk. In the alternative, a bank letter of credit may be posted as ascribed in Section 1230.12 paragraph A of the Zoning Code or, a bank cashier's check made payable to the Village of Lodi in the sum of One Thousand Dollars (\$1,000.00) may be posted to satisfy this requirement.

The foregoing shall not apply to a person making repairs in sidewalks adjacent to his property.

2.      Criteria for Sidewalk Replacement.

The existing sidewalk section or sections shall be deemed unacceptable and required to be removed and replaced when any one of the following conditions exists:

- a. The sidewalk holds water.
- b. Five percent of any sidewalk section is missing.
- c. Twenty-five percent of the sidewalk section is cracked.
- d. There is a minimum of one inch vertical separation of a section. If a section can be raised or lowered to make the sections adjacent to it conform with the standard set forth herein, the section may be raised or lowered and need not be replaced.
- e. There is an existing obstruction in the present sidewalk (i.e. fire hydrant, tree, pole, guy wire, etc.) requiring pedestrians to maneuver to avoid the obstruction.
- f. If seventy-five percent of the frontage shall be replaced or repaired to conform with the specifications if the sidewalk does not so conform.

3.      Sidewalk replacement.

Removal and replacement of existing sidewalk shall conform to the standard detail as shown on drawing No. 1 or No. 2.

**Section 9      Miscellaneous.**

1.      The placement of all new and existing sidewalks shall be as uniform as possible, giving due consideration to existing structures, construction engineering considerations, the slope of the land, and other features of the property and road right-of-way, so as to provide for the continuous and reasonable path for the sidewalks.
  
2.      Should a property owner disagree with the determination of the Street Superintendent, the property owner may appeal the decision of the Superintendent to Council. The appeal must be made in writing to the Village Clerk/Treasurer within fifteen days (15) of notice or within fifteen days (15) of the event giving rise to the disagreement with the Street Superintendent. Once the notice of appeal is filed, the deadline as specified herein shall be extended by the amount of time needed by Council to make a determination of the appeal.

**Adopted pursuant to Ordinance No. 1826**